

C-FORCE™ Compressors

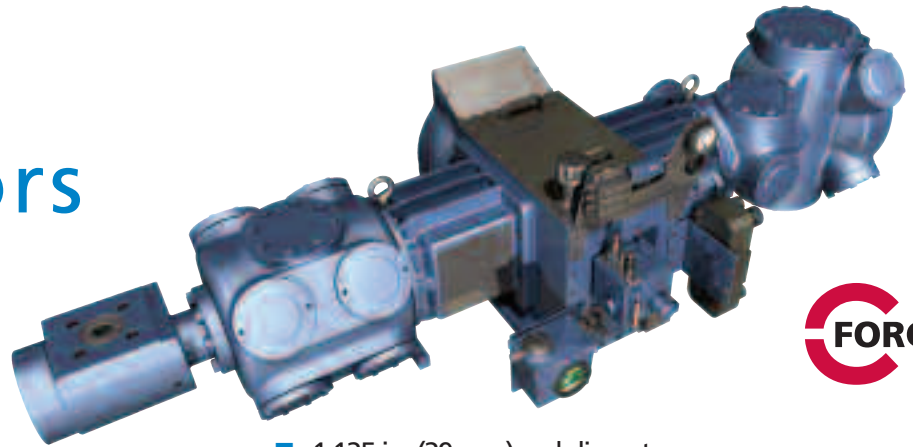

- Reciprocating, balanced, couple-free
- 1 - 4 cylinders
- 3 in. (76 mm) stroke, up to 1800 RPM
- 900 fpm (4.6 m/s) piston speed @ 1800 RPM
- 1.125 in. (29 mm) rod diameter
- 13,000 lb (58 kN) internal gas rod load
- Optional class B and C distance pieces for sour gas service
- Reduced vibration

Superior C-FORCE Specifications Reciprocating, true-balanced, couple-free

	C-FORCE 32	C-FORCE 34
No. of Cylinder Throws	2	4
Frame HP @ 1800 RPM	290 hp (216 kW)	580 hp (432 kW)
RPM Range	850 - 1800	850 - 1800
Stroke	3 in. (76 mm)	3 in. (76 mm)
Rod Diameter	1 1/8 in. (29 mm)	1 1/8 in. (29 mm)
Max Internal Gas Loads		
Tension (MGRT)	13,000 lb (58 kN)	13,000 lb (58 kN)
Compression (MGRC)	13,000 lb (58 kN)	13,000 lb (58 kN)
Net Rod Load	11,000 lb (49 kN)	11,000 lb (49 kN)
Total Peak-to-Peak	21,000 lb (93 kN)	21,000 lb (93 kN)
Piston Speed @ 1800 RPM	900 fpm (4.57 m/s)	900 fpm (4.57 m/s)
Lube Oil Flow Rate	10 gpm (38 liter/min)	10 gpm (38 liter/min)
Sump Capacity	4 gal (15 liter)	10 gal (38 liter)
Frame Wt. w/ Crosshead Guides	1,200 lb (544 kg)	2,000 lb (907 kg)

Note: Standard equipment, specifications and data are subject to change without notice.



Optional bell housing connection (SAE#1) between driver and compressor reduces misalignment during transportation and minimizes dynamic misalignment during operation.



Couple-free, balanced design minimizes vibration and piping fatigue.

Standard Equipment

- **Frame:** One-piece, ductile iron, heavily ribbed casting with tie-bolt construction. Aluminum top and end covers.
- **Crankshaft:** Forged or billet heat-treated SAE 4140 steel. Nitrided and balanced for long life and smooth operation. Centerline from bottom of the frame is 10 1/4 inches (26 cm).
- **Bearings:** Precision, split-shell, steel backed, tri-metal, main and connecting rod bearings. Held in place by 2- or 4- bolt bearing caps.
- **Connecting rods:** Precision machined and balanced, 4140 steel, rifle-drilled for crosshead pin lubrication.
- **Crosshead:** One-piece ductile iron, babbitt faced.

- **Crosshead Guides/Distance Pieces** available: Type A, B, and C.
- **Crankshaft:** Unique couple-free design puts opposing compressor throws directly in line eliminating most vibration. Enables use in vibration sensitive applications such as offshore platforms and trailer-mounted mobile units.

- **Lubrication System:** Crankshaft gear-driven oil pump, system relief valve, crankcase strainer, spin-on type full-flow oil filter, filler/breather, oil level sight gauge, and oil pressure gauges. Pressurized suction cylinder lubrication system which includes: stainless steel tubing and fittings, divider block, and lubricator flow meter and no-flow shut-down.
- **Special tools** needed for field maintenance

Compressor Cylinder Sizing Made Easy with COMPASS Software.



COMPASS is another Superior® Compressor exclusive! The most comprehensive and flexible sizing program available, COMPASS is user-friendly and Microsoft® and Windows® based. COMPASS can make a preliminary sizing and cylinder selection. The user can then refine the selection to include specific options desired. This can be followed by detailed performance calculations based on the equipment selected and can include ranges of conditions, dynamic rod load calculations, and performance curves.

To download the COMPASS software (at no charge), visit www.c-a-m.com

16250 Port Northwest Drive
Houston, TX 77041
Telephone: (713) 890-1300
Visit our web site at: www.c-a-m.com/cs

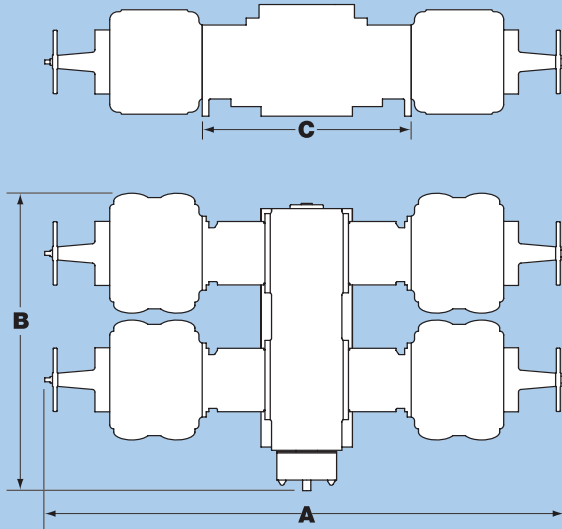

Model - C-FORCE	C-FORCE 32	C-FORCE 34
A width	8'2" (249 cm)	8'2" (249 cm)
B length	2'8" (81 cm)	4'8" (142 cm)
C frame width	3'4" (102 cm)	3'4" (102 cm)
A) Dimensions correspond to a Superior® C-FORCE Series frame with 7.125" cylinders.		
B) Dimensions correspond to a Superior® C-FORCE frame without bell housing.		
C) Dimensions correspond to a Superior® C-FORCE frame with Type A crosshead guides.		



Optional: Vari-valve clearance assembly in place of valve spacers; allows online crank-end clearance adjustment.

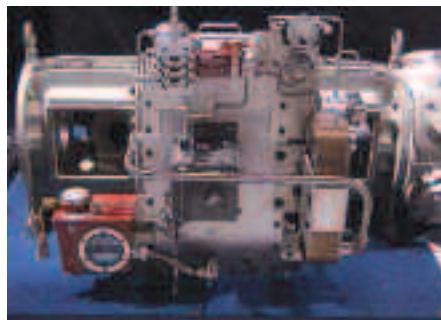

Optional: Factory installed and tested lubrication system offering oil cooler, oil level controller, lubricator no-flow shut-down, & manifold.

Superior® is a registered trademark of Cameron Corporation.

TC 0005 5M 09/06
Copyright © 2006 Cameron Corporation
Printed in U.S.A.



SUPERIOR®