

Representación exclusiva en España

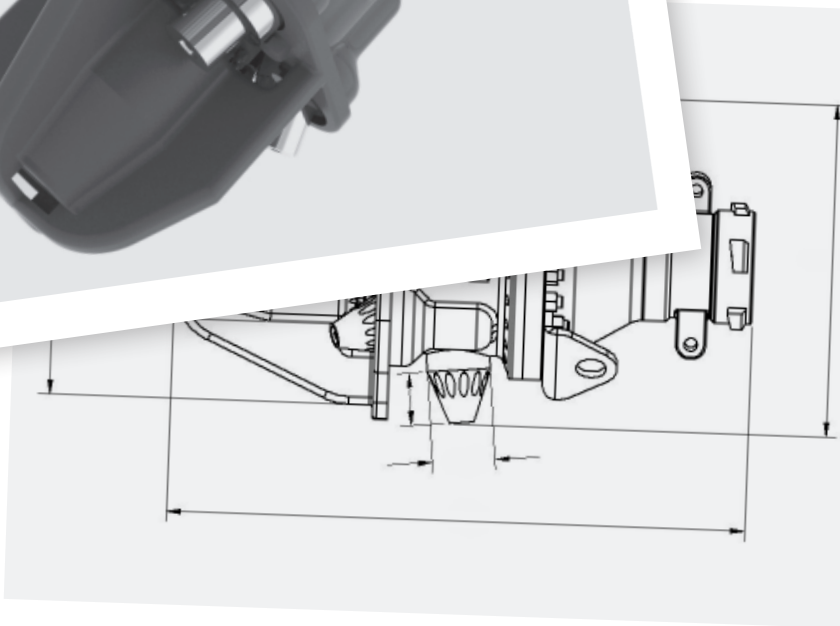

SOLJET ENERGIA s.a.

Paseo de la Castellana 154, 1 Izq. 28046 Madrid
Tel: 91 458 7732 – www.soljet.com



Auto-Switch Coke Cutting Tool

Technical Specifications

The innovative DeltaValve® Auto-Switch Coke Cutting Tool provides a high level of safety during de-coking operations by allowing the cutting tool to remain in the drum during switching of cutting/boring modes. Performance of the cutting nozzles are optimized for each pump pressure and drum diameter combination. For long term reliability, all internal mechanisms are isolated from exposure to cutting water and coke fines. Optional remote verification of cutting/boring mode is available.

Construction: Cast
Metallurgy: SA-487 CA6NM
Connections: Engineered to plant specifications
Cutting Water Pressures: 500 - 5400 PSI

Switch Force: Nitrogen spring
Dimensions: 32 3/8" X22"
Weight: 850 lbs. +/-

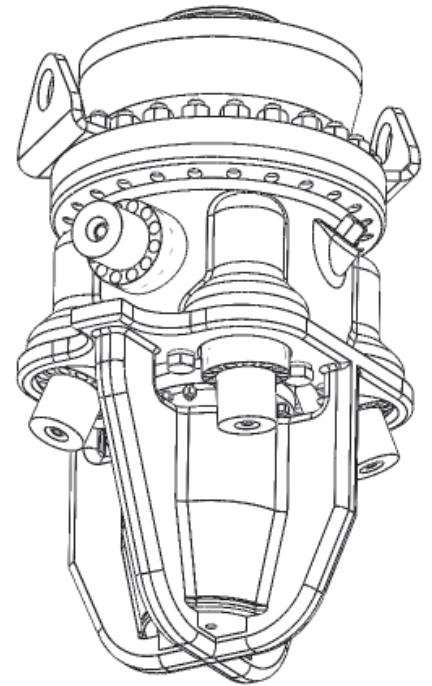

Patents:
USA 7,117,959 7,473,337 5,816,787
Russia 2343178

Other US and international patents pending

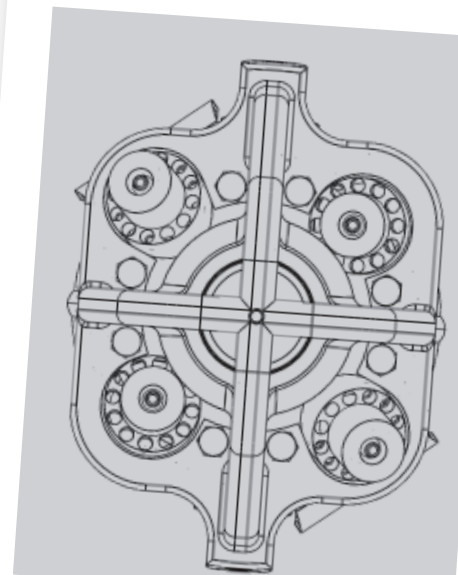
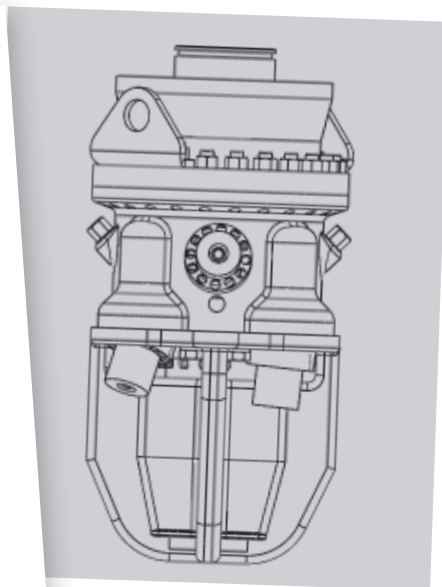
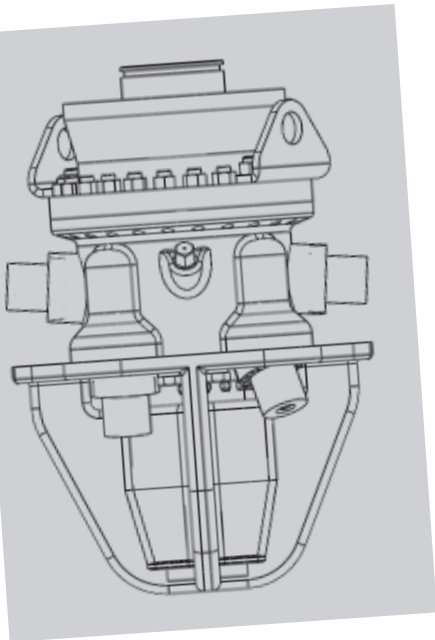

DeltaValve (USA)

857 West, South Jordan Parkway,
South Jordan, Utah 84095
Ph. 801.984.1000 Fax 801.984.1001

DeltaValve Corporation (Canada)

7712 - 56th Street S.E.
Calgary, Alberta T2C 4S9
Ph. 403.543.2244 Fax 403.543.2240

1.888.DELTAVALVE www.deltavalve.com info@deltavalve.com

**CURTISS
WRIGHT**
Flow Control Company
DeltaValve