

Representación exclusiva en España

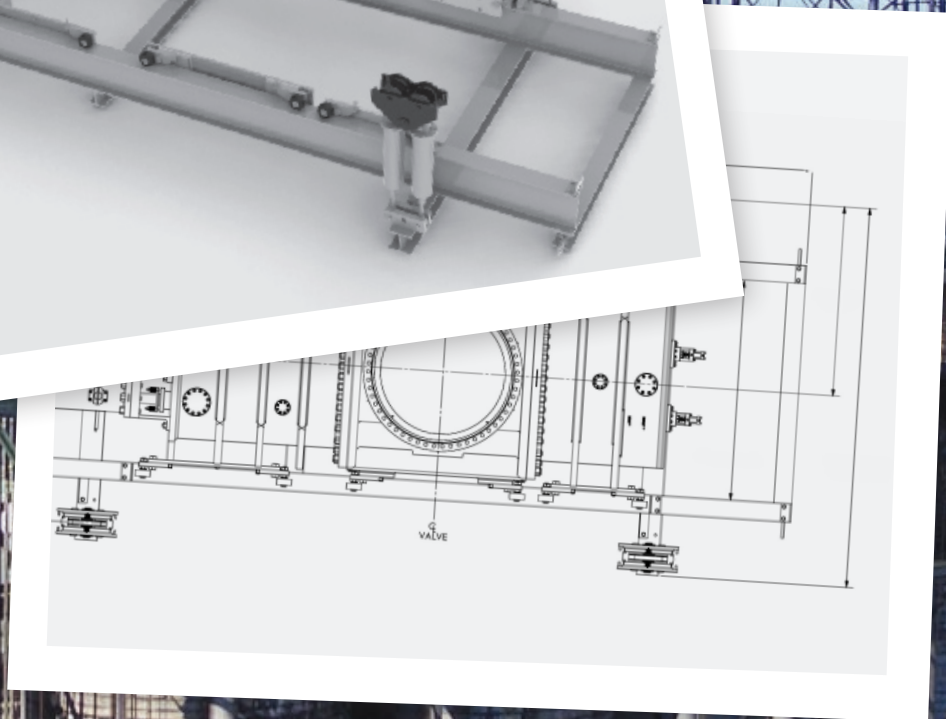

SOLJET ENERGIA s.a.

Paseo de la Castellana 154, 1 Izq. 28046 Madrid
Tel: 91 458 7732 – www.soljet.com

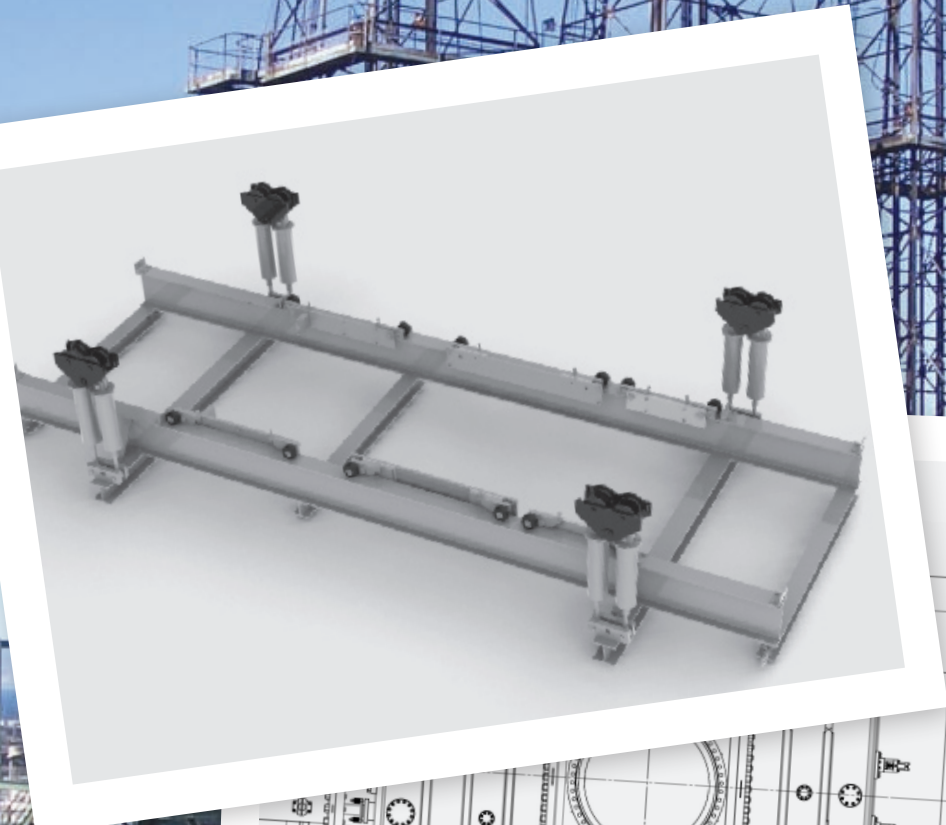

DeltaGlide™ Technical Specifications

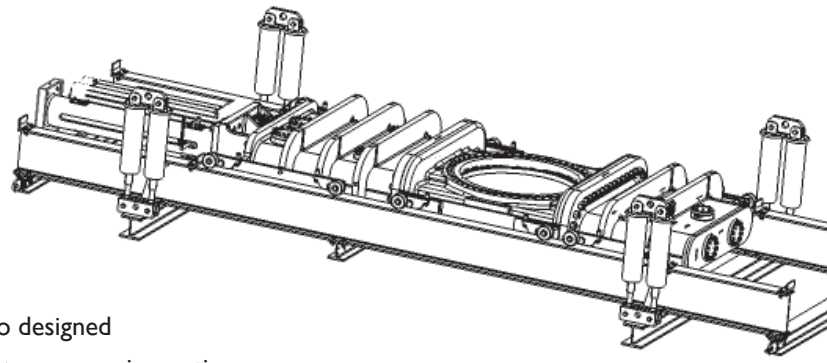

The DeltaGlide support and maintenance system is designed to facilitate installation of the DeltaGuard® unheading device. It is also designed to maintain alignment of separated valve components during maintenance or inspection.

Construction:	Fabricated
Metallurgy:	A992 HSLA structured carbon steel to -20F (optional A516 Gr70 to -55F)
Dimensions:	L 400" x W 176" x H 36"
Weight:	15,000 lbs. +/-
Support:	Engineered spring hanger (Optional: DeltaLift™ hydraulic vertical lift system with positive lockout)
Function:	System designed to support device and accommodate vertical and lateral drum movement during cycles Facilitates disassembly of DeltaGuard device on the switch deck
Maintainability:	Reduce down time and increase personnel safety

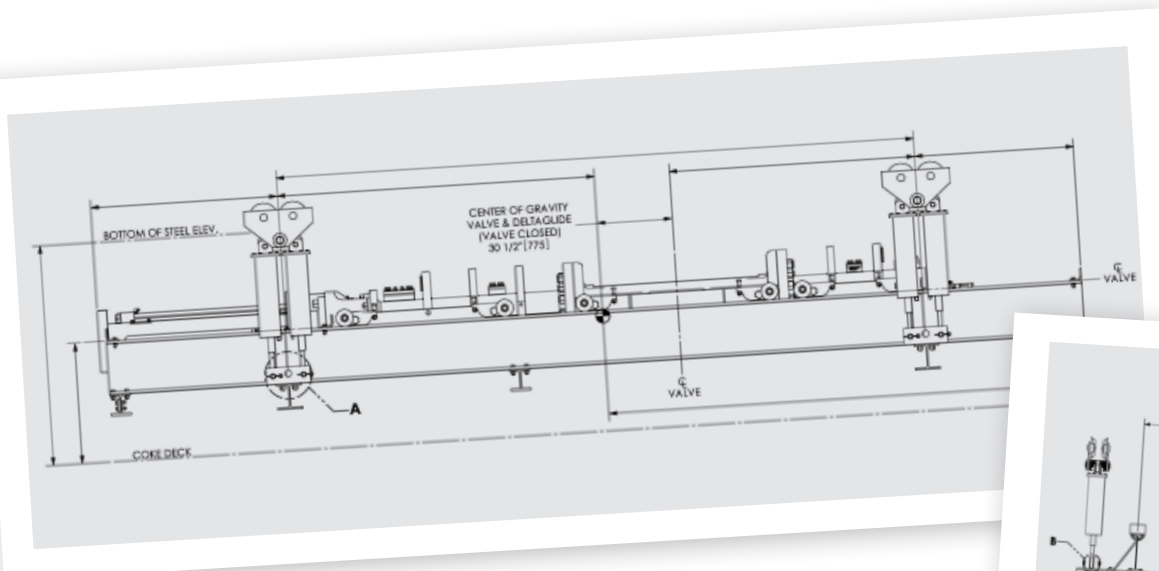

Patents:
USA 7,357,848
Russia 2328516

Other US and international patents pending

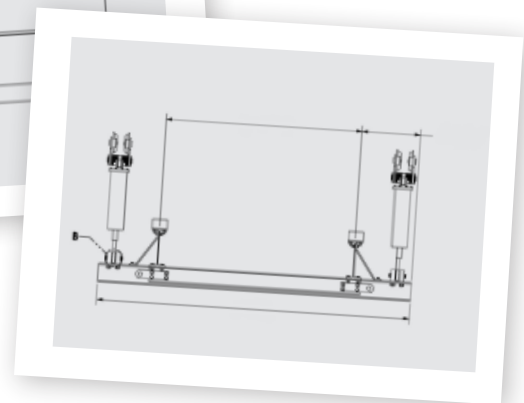

DeltaValve (USA)
857 West, South Jordan Parkway,
South Jordan, Utah 84095
Ph. 801.984.1000 Fax 801.984.1001

DeltaValve Corporation (Canada)
7712 - 56th Street S.E.
Calgary, Alberta T2C 4S9
Ph. 403.543.2244 Fax 403.543.2240



1.888.DELTAVALVE www.deltavalve.com info@deltavalve.com