

Range of products and services





### **Intelligent boiler technologies and services to get the best out of your fuels.**

For many years, the name Standardkessel Baumgarte stands for intelligent boiler technologies and services. What characterises us, is a matchless broad know-how in the various types of thermal waste recovery processes. A knowledge that becomes more and more popular in times of high energy costs and running short resources. So, it is not a surprise that new solutions to recover energy are required and more and more clients decide in favour of Standardkessel Baumgarte.

Under the umbrella of Standardkessel Power Systems Holding GmbH, the Standardkessel company holds a market-leading position, in particular, in the prospective segment of biomass power plants whereas the Baumgarte company is the first address for waste and refuse derived fuels.

We are happy to place our dual competence at your disposal. Get in touch with us.



**Standardkessel Baumgarte Group**

**Content**

**NEW PLANTS**

- Standardkessel GmbH**
- Baumgarte Boiler Systems GmbH**

- 04** Energy from waste
- 14** Energy from biomass
- 20** Energy from waste heat

**SERVICE**

- Standardkessel Baumgarte Service GmbH**
- EPCo Service**
- emc Germany GmbH**
- emc Kazakhstan**

- 26** Energy from primary fuels
- 32** Plant-services from A to Z
- 34** Innovative technologies
- 38** Customer references



Whether for environmental or economic reasons, careful handling of resources such as household waste and household-type industrial waste and residues from industrial production processes is nowadays one of the most demanding challenges. It is undeniable that a lot can still be gained where these resources are concerned. This has already been proved by the sophisticated state-of-the-art Baumgarte boiler and firing plants for many years. From that time onwards, the resulting economy

# PUTTING RESIDUES TO WORK: ENERGY FROM WASTE

04/05



of primary energy sources contributes to the reduction of CO<sub>2</sub> emission. If applied efficiently, these sources help to convert the heat generated during thermal disposal processes into useful energy, i.e. in the form of steam or hot-water that can be used for power generation or as process and restricted heat respectively. A new development is the treatment of waste in specially designed treatment plants. Apart from reclaimed materials (e.g. metals), refuse-derived fuels are also discharged along with the waste steam which Baumgarte uses to generate decentralised power, steam and heat in the best possible way.



## SOURCES OF ENERGY

### HOUSEHOLD AND HOUSEHOLD-TYPE INDUSTRIAL WASTE

The thorough disposal of household waste and household-type industrial waste is still a current issue. The shortage in global energy resources and the increasing concern about our environment requires that we direct our attention to this task by means of the most innovative plant technology.

<b>Fuel:</b>	Household and household-type industrial waste
<b>Performance Range:</b>	Steam parameter up to 140 t/h - 500°C - 100 bar
<b>Boiler technology:</b>	<ul style="list-style-type: none"><li>• Steam generator operating in natural circulation with two or three vertically arranged radiation passes and a downstream convective pass.</li><li>• The first, second or third boiler pass are in empty pass construction and form the combustion and radiation area. The vertical or horizontal convective boiler pass is equipped with the superheater, evaporator and economiser convective heating surfaces.</li><li>• All convective heating surfaces can be cleaned while running using rapping devices or soot blowers.</li><li>• Depending on the profile for requirement, boiler constructions with the installation of 3 or 4 passes can be applied.</li><li>• The superheated steam temperature control is carried out by means of an injection cooler between the superheater heating surfaces.</li></ul>
<b>Combustion system:</b>	<ul style="list-style-type: none"><li>• Air or water-cooled pusher-type grate with ram feeder</li><li>• The primary air is blown in below the grate. The individual zones can be controlled separately.</li><li>• The secondary air is injected via nozzle trays arranged in the first and rear wall of the furnace area.</li></ul>
<b>Flue gas treatment:</b>	<ul style="list-style-type: none"><li>• Depending on the requirements, the following is installed, e.g. electrostatic precipitator or cyclone plant with downstream fabric filter. According to emission regulations, the flue gas is conditioned by means of absorbers.</li><li>• Alternatively, a wet flue-gas washing can be installed.</li></ul>

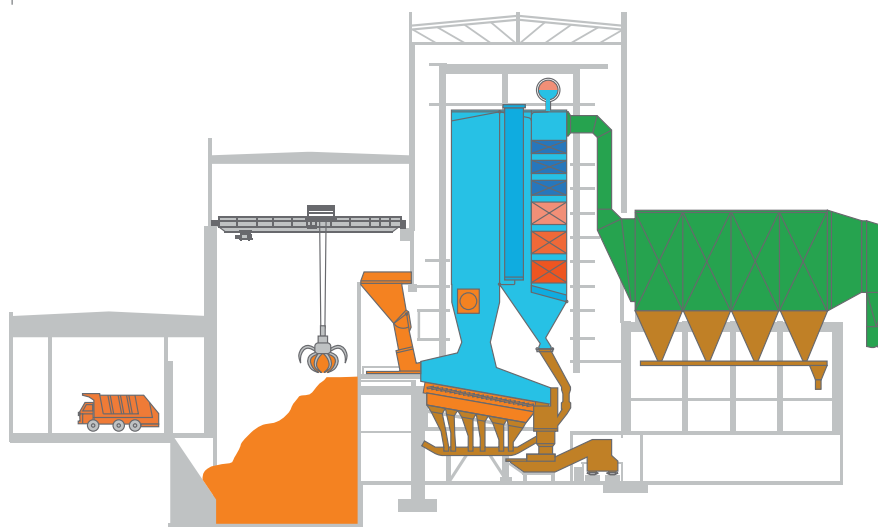

Example of a plant fired using household and household-type industrial waste



## Sample Reference Bremen, Germany

### The Task

A new plant with an essentially higher capacity was to install at the location of boiler 1 in the waste-to-energy plant Bremen operated by the Abfallbehandlung Nord GmbH. Due to the existing building structures a plant had to be designed which was able to fulfill the tasks in consideration of the procedural master conditions without the requirement of substantial modifications. The consortium Baumgarte Boiler Systems GmbH with its associated company LLS Standardkessel GmbH obtained the contract for the delivery of the steam generator including the combustion system, the steel structure and all required auxiliary plants with accessories.

### Technical Project Information

Number of Lines:	1
Fuel:	Household and Industrial Waste
Heating Value (min./max./nom.):	8.0 / 15.0 / 8.0 MJ/kg
Fuel Throughput each (min./max./nom.):	13.2 / 24.2 / 22 t/h
Rated Thermal Input:	73.8 MW
Steam Capacity:	97.0 t/h
Steam Pressure:	21.4 bar g
Saturated Steam Pressure:	21.4 bar g
Saturated Steam Temperature:	217 °C
Feed Water Temperature:	130 °C
Flue Gas Flow:	117,990 m <sup>3</sup> i. N./h
Exhaust-Gas Temperature:	230 °C
Operating Approval:	17. BImSchV
Year of Commissioning	2005

### The Solution

The task was fulfilled by the design of a saturated-steam generator in vertical construction suspended above the new pusher-type grate. This system in its three-pass construction was arranged with the heating surfaces in the last boiler pass. The cleaning of the heating surfaces is effected by means of sootblowers.

### Scope of Supply

- Saturated-Steam Generator with Fittings
- Heating Surface Cleaning plant as Sootblower
- SNCR
- Refractory Lining
- Thermal Insulation
- Boiler Supporting Structure with Stairs and Platforms

### Services

- Engineering incl. Approval and Official Engineering
- Erection and Commissioning
- Trial Run

# SOURCES OF ENERGY

## REFUSE-DERIVED FUELS

The mainstay of the closed-loop material economy is the recovery of refuse-derived fuels from waste. This fuel can be used in power plants generating municipal energy as well as in industrial power plants for covering process-energy requirements. Here, Baumgarte Boiler Systems offers future-oriented technologies for firing and boiler plants.

<b>Fuel:</b>	Refuse-derived fuels
<b>Performance Range:</b>	Steam parameters up to 140 t/h - 500°C - 100 bar
<b>Boiler technology:</b>	<ul style="list-style-type: none"><li>• Steam generator operating in natural circulation with two or three vertically arranged radiation passes and a downstream convective pass.</li><li>• The first, second or third boiler pass are in empty pass construction and form the combustion and radiation area. The vertical or horizontal convective boiler pass is equipped with the superheater, evaporator and economiser convective heating surfaces.</li><li>• All convective heating surfaces can be cleaned while running using rapping devices or soot blowers.</li><li>• Depending on the profile for requirement, boiler constructions with the installation of 3 or 4 passes can be applied.</li><li>• The superheated steam temperature control is carried out by means of an injection cooler between the superheater heating surfaces.</li></ul>
<b>Combustion system:</b>	<ul style="list-style-type: none"><li>• Air and/or water-cooled pusher-type grate firing with ram feeder</li><li>• The primary air is fed underneath the grate - divided into several separately controllable zones.</li><li>• The secondary air is injected via nozzle trays arranged in the front and rear wall of the furnace area.</li></ul>
<b>Flue gas treatment:</b>	<ul style="list-style-type: none"><li>• Depending on the requirements, the following is installed, e.g. electrostatic precipitator or cyclone plant with downstream fabric filter. According to emission regulations, the flue gas is conditioned by means of absorbers.</li><li>• Alternatively, a wet flue-gas washing can be installed.</li></ul>

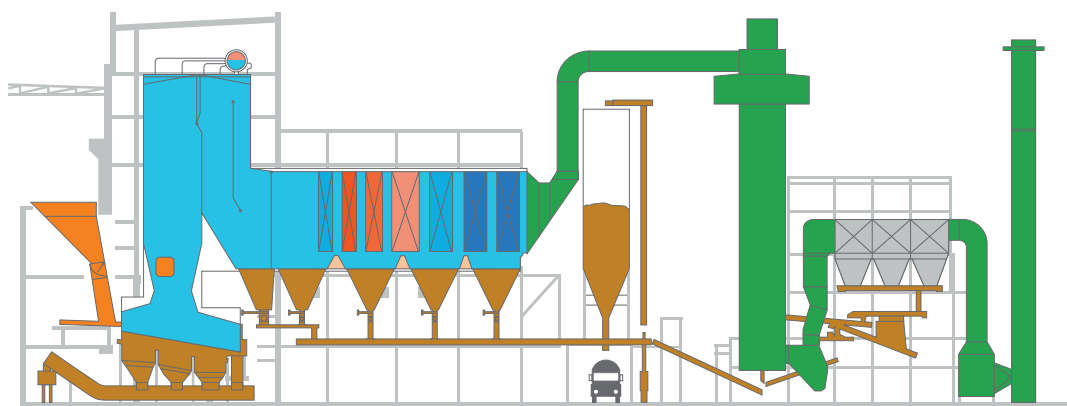

Example of a plant fired using refuse-derived fuels



## Sample Reference Stavenhagen, Germany

### The Task

In order to supply the production facilities of a large food supplier economically with energy, a combustion line together with all auxiliary equipment was to be designed in consideration of the prevailing geographic conditions. Meeting the requirements for high availability, the plant concept was developed on the basis of comparable realised plants. Besides the steam generator and combustion system the order placed by Nehlsen AG, acting as waste-management Company, investor and plant operator, comprised further plant components and services.

### The Solution

On the basis of comparable realised RDF-plants, Baumgarte Boiler Systems GmbH developed a concept which conforms to the prevailing conditions and meets the requirements for a high availability period. After a long planning phase as from February 2004 Nehlsen AG and Baumgarte Boiler Systems GmbH finally signed the contract in February 2005. The very challenging time schedule was kept so that the commissioning, the performance record and plant takeover took place in consideration of the agreed conditions in the second quarter of the year 2007.

### Technical Project Information

Number of Lines	1	
Fuel:	Refuse Derived Fuel (RDF)	
Heating Value (min./max./nom.):	11 / 14 / 11	MJ/kg
Fuel-Throughput (min./max./nom.):	6.6 / 12.46 / 12.2	t/h
Heat Input:	47.5	MW
Steam Capacity:	54.8	t/h
Steam Pressure:	42.0	bar g
Steam Temperature:	400	°C
Feedwater Temperature:	125	°C
Flue-Gas Flow:	95,000	m <sup>3</sup> i. N./h
Exhaust-Gas Temperature:	170	°C
Operating Approval:	17. BlmSchV	
Year of Commissioning:	2007	

### Scope of Supply

Complete combustion line from fuel-feed hopper up to stack outlet:

- Combustion Grate System (water-cooled), SNCR
- Ignition and Auxiliary Burners
- Fuel Oil Storage Tank and Fuel Oil Supply
- Slag-Removal Systems
- Main-Steam Generator incl. Fittings and Heating-Surface Cleaning System
- Flue-Gas Cleaning Plant with Exhaust-Gas Plant
- Ash an Residue Systems
- Electro, Instrumentation and Control Engineering, Process Control Technology
- Steel Structure with Stairs and Platforms
- Boiler House and Part Building Service

### Services

- Engineering incl. Approval and Official Engineering
- Erection and Commissioning
- Trial Run

# SOURCES OF ENERGY

## SOLID INDUSTRIAL RESIDUES

The production residues as alternative energy carrier will be more interesting at the globally increasing production of utility goods. We supply the equivalent plants to enable the meaningful and environment-friendly use of industrial residues in future: for the efficient power generation.

<b>Fuel:</b>	Production residues, industrial residues, used tyres
<b>Performance Range:</b>	Steam parameters up to 100 t/h - 500°C - 100 bar
<b>Boiler technology:</b>	<ul style="list-style-type: none"> <li>• Steam generator in boiler systems with natural circulation with several vertically arranged boiler passes.</li> <li>• The first boiler pass is formed as open pass and is divided into furnace and radiation chamber. Superheater, evaporator and economiser convection heating surfaces are installed in all further boiler passes.</li> <li>• All convection heating surfaces can be cleaned during operation with soot blowers.</li> <li>• The superheated steam temperature control is carried out by means of an injection cooler between the superheater heating surfaces.</li> </ul>
<b>Combustion system:</b>	<ul style="list-style-type: none"> <li>• Air and water cooled moving-grate stoker firing with pusher feeding.</li> <li>• The primary air is fed underneath the grate - divided into several separately controllable zones.</li> <li>• The secondary air injection is carried out via nozzle rows in the front and rear wall of the furnace.</li> </ul>
<b>Flue gas treatment:</b>	Depending on the requirement the following devices will be installed: electrostatic precipitator or cyclone plant with downstream fabric filter. In dependency of the antipollution regulations a flue gas conditioning with adsorbents.

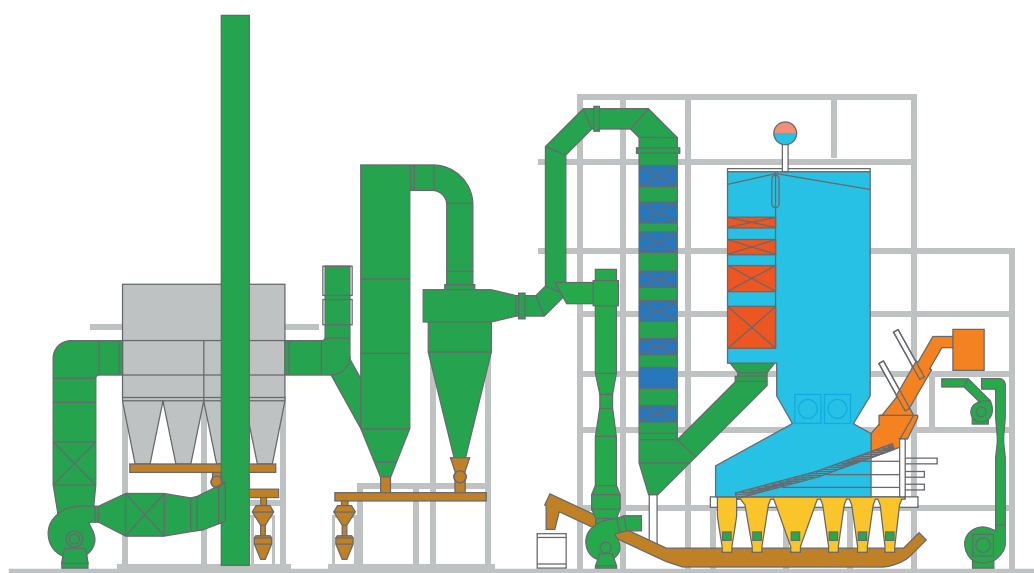

Example of a plant fired using solid industrial materials



## Sample Reference Polgar, Hungary

### The Task

In Hungary, the company TechCon disposes of used tyres and production residues from the production of tyres. The accumulating substances to be disposed of, such as passenger car tyres, truck tyres and the tyres of heavy agricultural machines are to be disposed of by thermal means and the inherent energy is to be converted into electricity. The residual substances accumulating as a result of incineration as well as flue-gas cleaning are either to be treated to obtain valuable substances or to be sent to landfills.

### The Solution

TechCon placed an order with Hungarian company Csöszer as the general contractor for the supply of a power plant on

a turnkey basis. The order for the thermal part, consisting essentially of the fuel conveying system, the steam generator with grate stoker and flue-gas cleaning was secured by Standardkessel. The tyre handling equipment separates and transports the whole tyres from the storage area to the feed device for the firing system. The heart of the plant is made up of the underfeed stoker and the vertically arranged natural circulation boiler which generates the superheated steam for feeding into the connected steam turbine. The flue gases produced are freed of all pollutants in a flue-gas cleaning plant based on the dry sorption process and are discharged into the atmosphere via a stack after cleaning.

### Technical Project Information

Number of Lines	1
Fuel:	Used Tyres
Low Heating Value (min./max./nom.):	28.0 / 36.0 / 31.4 MJ/kg
Fuel Throughput per Line (min./max./nom.):	2.5 / 3.5 / 2.9 t/h per Line
Rated Thermal Output:	25.3 MW
Electrical Power Output:	5.6 MW
Steam Capacity:	27.4 t/h
Steam Temperature:	503 °C
Steam Pressure:	81 bar g
Feed Water Temperature:	130 °C
Rated Flue Gas Volume (nom.):	55,000 m <sup>3</sup> i. N./h
Flue Gas Temperature:	220 °C
Electrical Power Output:	14 MWel
Operating Approval:	17. BImSchV
Year of Commissioning:	2009

### Scope of Supply

- Tyre handling system
- Firing system
- Steam generator
- Flue-gas cleaning system
- Ancillary plants
- Structural steelwork, stairs and platforms

### Services

- Engineering incl. Licensing Engineering and Engineering for official Permits
- Assembly and Commissioning
- Trial-Run

# SOURCES OF ENERGY

## GASEOUS OR LIQUID FUELS

One of the more pleasant side effects of the increases in the production of consumer goods around the world is that the industrial waste this produces can be used as an alternative fuel for power generation. It's environmentally-friendly and efficient, as the numerous plants set up by Standardkessel prove.

<b>Fuel:</b>	Gaseous or liquid residues
<b>Performance Range:</b>	Steam parameters up to 100 t/h - 500°C - 100 bar
<b>Boiler technology:</b>	<ul style="list-style-type: none"> <li>• Steam generator in boiler systems with natural circulation with several vertically arranged boiler passes.</li> <li>• The first boiler pass is formed as open pass and is divided into furnace and radiation chamber. Superheater, evaporator and economiser convection heating surfaces are installed in all further boiler passes.</li> <li>• All convection heating surfaces can be cleaned during operation with soot blowers.</li> <li>• The superheated steam temperature control is carried out by means of an injection cooler between the superheater heating surfaces.</li> </ul>
<b>Combustion system:</b>	Low NOx industrial / powerstation firing systems. The choice and installation of the burners is carried out depending on the required capacity respectively on the fuel characteristics. The burners are installed in the surrounding walls of the combustion chamber.
<b>Flue gas treatment:</b>	Depending on the requirement the following devices will be installed: electrostatic precipitator or cyclone plant with downstream fabric filter. In dependency of the antipollution regulations a flue gas conditioning with adsorbents.

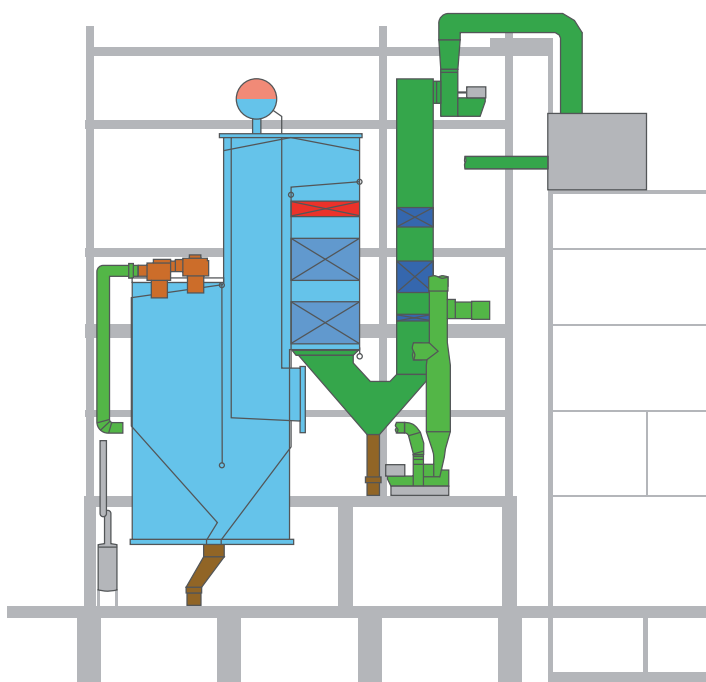

Example of a plant fired using liquid and gaseous industrial materials



## Sample Reference Sisseln, Switzerland

### The Task

In Switzerland, the company DSM disposes production residues from vitamin production.

The accumulating chemical liquids shall be disposed by thermal means and the energy contained therein shall be efficiently converted into process steam.

### The Solution

DSM placed an order with Standardkessel to supply the waste incineration plant.

The firing system for various fuels and the vertically arranged natural circulation boiler generating superheated steam as process steam, are building the core of the plant.

The produced flue gases first flow through a filter unit and then through a flue-gas cleaning system working according to the wet sorption process. In that process the flue gases are freed of all noxious substances and discharged into the atmosphere via a stack.

Parts of the flue gas cleaning plant were already existing before the order was placed and were revamped and/or optimised within the scope of the construction of the new plant by Standardkessel.

### Technical Project Information

Number of Lines	1
Fuel:	Liquid Production Residues, Waste Gas, Natural Gas
Low Heating Value (min./max.):	24.0 / 42.0 MJ/kg
Fuel Throughput (liquid):	1.5 t/h
Rated Thermal Input:	17 MW
Steam Capacity:	20 t/h
Steam Temperature:	360 °C
Steam Pressure:	33 bar g
Feed Water Temperature:	105 °C
Waste Gas Temperature:	100 °C
Operating Approval:	17. BlmSchV/SVTI
Year of Commissioning:	2003

### Scope of Supply

- Steam Generator
- Firing System for Waste Gas and 16 different liquid Fuels
- Fuel Supplying Systems
- SNCR-System
- Air and Flue Gas Ducts
- Complete Piping
- Electrical Equipment, Measuring and Control System
- Steel Construction for Boiler House including Front

### Services

- Engineering
- Erection
- Commissioning



High costs for primary energy sources such as oil and natural gas and, most notably, environmental concerns, have created a real boom in the environmentally-friendly generation of energy from biomass. The plants constructed by Standardkessel have been validating for many years that renewable energy technologies are also cost-efficient. Additional investment incentives come from programs promoting the use of renewable



# A MATURE TECHNOLOGY: ENERGY FROM BIOMASS

14/15



sources of energy which have been launched in most European countries in response to climate change and the depletion of fossil fuels.

The list of useable biofuels is long, spanning from wood and bark up to rice husks and olive pulp. Efficient conversion of these fuels is a result of longstanding process expertise, a command of fuel chemistry and tried and tested boiler systems.

It's no wonder that Standardkessel is the European leader in the development and construction of biomass plants.



# SOURCES OF ENERGY

## WOOD

Wood has always been used for the generation of heat and energy. However, since the Renewable Energy Act (REA) fuel has become increasingly significant as an environmentally friendly energy source. And it's happening against a similar background throughout the world, not just in Europe.

<b>Fuel:</b>	Matured wood, waste wood, fresh wood, forest waste, tree prunings, peat, bark
<b>Performance Range:</b>	Steam parameters up to 120 t/h - 500°C - 100 bar
<b>Boiler technology:</b>	<ul style="list-style-type: none"> <li>• Steam generator in boiler systems with natural circulation with several vertically arranged boiler passes.</li> <li>• The first and the second boiler flues are designed as radiation passes building the combustion chamber and the radiation surfaces of the evaporator system. The following passes are equipped with superheater, evaporator and economiser bundles.</li> <li>• All convective heating surfaces can be cleaned by soot blowers during operation.</li> <li>• The superheated steam temperature control is carried out by means of an injection cooler between the superheater heating surfaces.</li> </ul>
<b>Combustion system:</b>	<ul style="list-style-type: none"> <li>• Pusher type grate system</li> <li>• The primary air is introduced under the grate system. The different air zones can be controlled independently from each other.</li> <li>• The nozzles for the secondary air injection are located at the front and rear boiler walls above the combustion chamber.</li> <li>• Use of recirculation gas</li> <li>• Injection of swarf</li> </ul>
<b>Flue gas treatment:</b>	<p>According to the requirements, e.g. following equipments are foreseen: cyclone system, bag house filter respectively electrostatic precipitators.</p> <p>Following the emission requirements a flue gas conditioning system can also be foreseen in dry, semi-dry or wet washing processes.</p> <p>Use of SNCR / SCR technology</p>

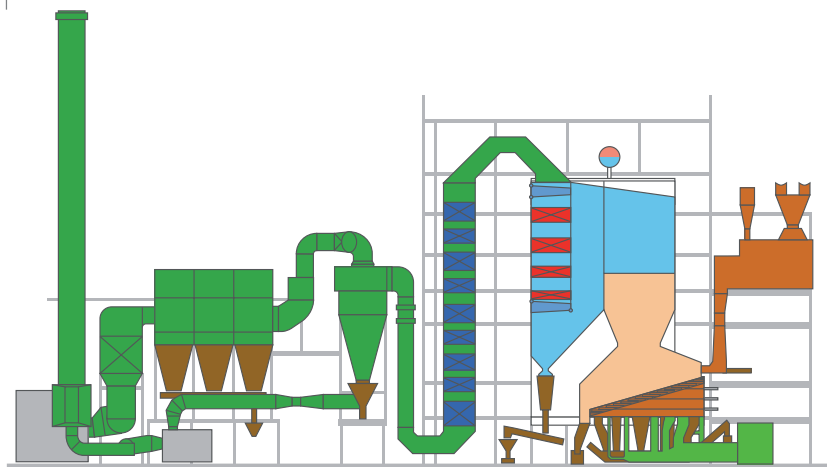

Example of a wood-fired plant



## Sample Reference Eberswalde, Germany

### The Task

At the Eberswalde location a new biomass-fired power plant (BMPP) was to be constructed in the harbour area. The task of the BMPP is to supply the surrounding households with electricity. Moreover, the co generation of process steam for supplying the surrounding business enterprises/production plants is planned. As the fuel for the BMPP, only fresh wood in accordance with the Biomass Ordinance is to be used. The order for implementation was placed with Standardkessel in July 2005.

### The Solution

In order to find a solution in keeping with the terms of reference, the plant was equipped with the following process equipment units. The delivery of the fuel is to be carried out

by means of trucks. From the receiving station the fuel is taken to a roofed-over outdoor storage area where it is put into intermediate storage. From the open air storage area, the fuel is conveyed by means of moving floors and conveyor belts to the boiler area.

The thermal part consists of grate stoker, steam generator and flue-gas cleaning system. The firing of the fuel is carried out via a three-compartment underfeed stoker. The steam generator is designed as a water-tube boiler in the vertical type of construction with natural circulation. In order to achieve optimum efficiency, there is an integral reheat stage. Flue-gas cleaning is carried out in a dry process by means of fabric filters. The electric energy generated in the turbine/generator is fed into the public grid.

### Technical Project Information

Number of Lines	1	
Fuel:	Wood	
Low Heating Value (min./max./nom.):	8.5 / 12.0 / 10.4	MJ/kg
Fuel Throughput (min./max./nom.):	11.0 / 24.0 / 22.0	t/h
Rated Thermal Input:	68	MW
Electrical Power Output:	20	MW
Steam Capacity:	68	t/h
Steam Temperature:	482	°C
Steam Pressure:	81 / 21	bar g
Feed Water Temperature:	105	°C
Rated Flue Gas Volume:	135,000	m <sup>3</sup> i. N./h
FG-Temperature:	160 / 200	°C
Operating Approval:	13. BlmSchV	
Year of Commissioning:	2006	

### Scope of Supply

Turn-key Biomass Power Station

- Fuel feed system
- Firing system / boiler / flue-gas cleaning system
- Water / steam circuit with reheat
- Steam turbine / generator/ cooling tower / cooling circuits
- Chemical water treatment
- Electrical instrumentation and control system
- Auxiliary plant units

### Services

- Engineering incl. Licensing Engineering and Engineering for official Permits
- Assembly and Commissioning
- Trial-Run

# SOURCES OF ENERGY

## OTHER BIOGENEOUS FUELS

Beside wood all other biogenous sources are demanded, if it deals with environmental, CO<sub>2</sub>-neutral power generation. We offer a wide range of applications in this area.

<b>Fuel:</b>	Olive waste, rice husks, other biogenous residues
<b>Performance Range:</b>	Steam parameters up to 140 t/h - 500°C - 100 bar
<b>Boiler Technology:</b>	<ul style="list-style-type: none"><li>• Steam generator in boiler systems with natural circulation with several vertically arranged boiler passes.</li><li>• The first boiler pass is formed as open pass and is divided into furnace and radiation chamber. Superheater, evaporator and economiser convection heating surfaces are installed in all further boiler passes.</li><li>• All convection heating surfaces can be cleaned during operation with soot blowers.</li><li>• The superheated steam temperature control is carried out by means of an injection cooler between the superheater heating surfaces.</li></ul>
<b>Combustion system:</b>	<ul style="list-style-type: none"><li>• Travelling grate firing with charging machine</li><li>• The primary air is fed underneath the grate - divided into several separately controllable zones.</li><li>• The secondary air injection is carried out via nozzle rows in the front and rear wall of the furnace.</li></ul>
<b>Flue gas treatment:</b>	Depending on the requirement the following devices will be installed: electrostatic precipitator or cyclone plant with downstream fabric filter. Dependent on the antipollution regulations a flue gas conditioning with absorbents.

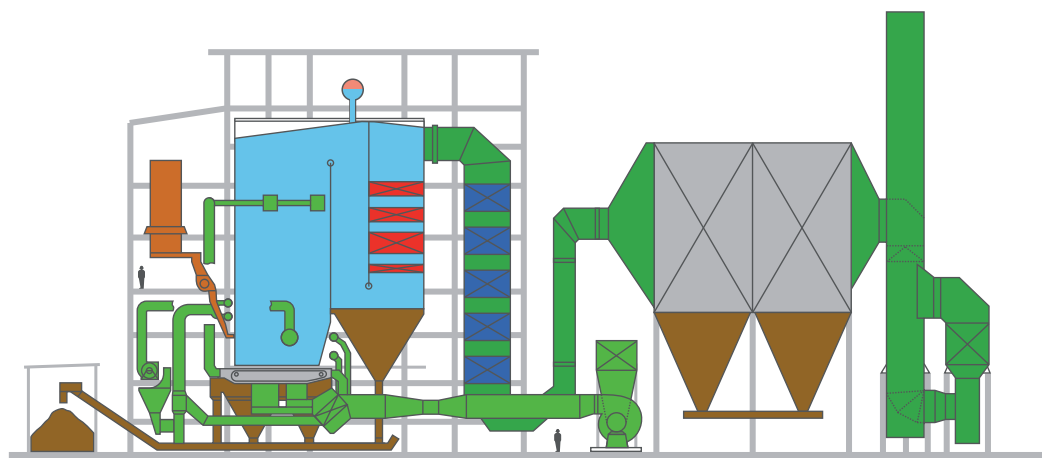

Example of a plant fired using the residue left after pressing olives



## Sample Reference Baena, Spain

### The Task

EL Oleicola El Tejar in Baena, Andalucia, is one of the largest olive oil producers in Spain. Until now, olive waste generated during the production process was disposed of on large waste disposal sites.

However, since Spanish legislation encourages the utilization of regenerative energies, using olive waste for generating electricity in a biomass power plant was found to be advantageous.

### The Solution

Standardkessel has developed the first European biomass power plant capable of using "alperujo"-olive waste generated

during the extraction of olive oil in a centrifugation process – as fuel. In December 1998, the contract for development and turn-key construction was concluded between Agroenergetica de Baena S.L. and Standardkessel.

The start-up, successful performance test run and approval took place in February, 2002 – faultlessly and in compliance with all contractually agreed-upon guarantees. Spanish and European legal requirements were not only fulfilled, but in terms of emissions, even surpassed in many cases. The maximum electrical output is 25 MW.

### Technical Project Information

Number of Lines	1	
Fuel:	Olive waste	
Low Heating Value (min./max./nom.):	9.2 / 15.1 / 10.1	MJ/kg
Fuel Throughput (min./max./nom.):	25.0 / 41.0 / 37.4	t/h
Rated Thermal Input:	105	MW
Electrical Power Output:	25	MW
Steam Capacity:	110	t/h
Steam Temperature:	455	°C
Steam Pressure:	63	bar g
Feed Water Temperature:	105	°C
Rated Flue Gas Volume:	161,890	m <sup>3</sup> i. N./h
FG-Temperature:	160	°C
Operating Approval:	EU Requirements	
Year of Commissioning:	2002	

### Scope of Supply

Turn-key Biomass Power Plant, specifically:

- Fuel Storage and Supply, including Diesel Oil Stock as Ignition and Auxiliary Fuel
- Steam Boiler with Grate Firing
- Flue Gas Purification
- Steam Turbine
- Water Treatment / Waste Water Treatment
- Cooling and Condensation System
- Required Systems such as Water/Steam Cycle, Pressurized Air System, Fire-Fighting System, including the necessary Tubing and Fittings
- System-related Electrical and Lighting Equipment

### Services

- Engineering incl. Permit and Authority Engineering
- Erection
- Commissioning



In many industrial production processes, the energy-consumption ratio is continuously rising. No surprise then, that „efficiency boosting“ is increasingly becoming the focus of production process design. Mounting energy costs worldwide only add to that.

# A HOT TOPIC: HEAT RECOVERY

20/21



The waste heat technologies developed by Standardkessel and Baumgarte have a highly positive effect on the energy balance - and on environmental protection as well, since the heat generated during the production process is further utilised: for example in conventional heat recovery boilers or heat recovery boilers behind gas turbines that are equipped with auxiliary firing, fresh air mode and flying takeover and therefore respond flexibly to a wide range of operating conditions.



# SOURCES OF ENERGY

## GT PROCESS

The heat recovery boiler downstream of gas turbines forms an important process package for the efficient utilisation of energy of the gas and steam turbine process. The boiler uses the turbine gases for steam generation and to increase the total efficiency of the plant therefore, the boiler will mostly be equipped with auxiliary firing.

<b>Heat source:</b>	Gas turbine exhaust gas
<b>Performance Range:</b>	Steam parameters up to 560 t/h - 560°C - 160 bar
<b>Auxiliary fuels:</b>	Coke-oven gas, blast-furnace gas, natural gas, light oil, production exhaust gases
<b>Boiler technology:</b>	<ul style="list-style-type: none"><li>• Steam generators with natural circulation in horizontal or vertical one or multi-pass construction with different pressure stages.</li><li>• Either designed as heat recovery boiler or equipped with auxiliary firing also suited for fresh air operation and „flying takeover“ between fresh air operation mode and gas turbine operation mode.</li><li>• The superheat steam temperature control is carried out by means of an injection cooler between the superheater heating surfaces.</li></ul>
<b>Combustion system:</b>	Industrial combustion systems as duct burners in the gas turbine exhaust duct or as in-duct burner in the combustion chamber of the boiler plant respectively. As gas turbine burner installed in the floor or in the surrounding walls of the water cooled combustion chamber of the boiler plant.

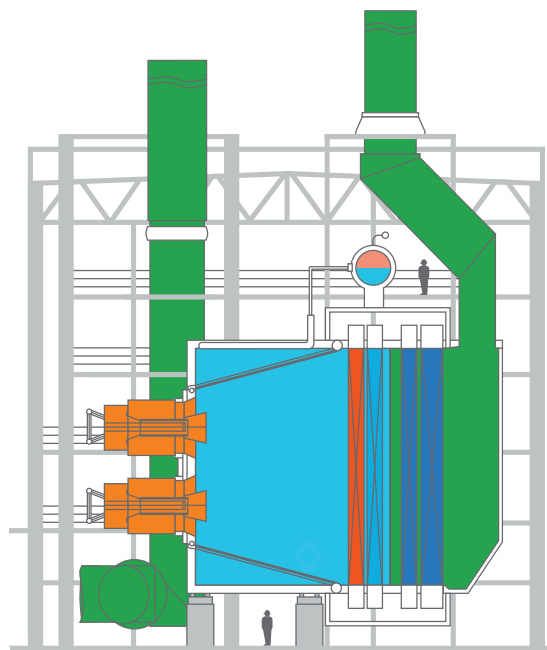

Example of a plant fired using the heat recovered from gas turbines



## Sample Reference Münster, Germany

### The Task

Stadtwerke Münster GmbH, a municipal utility company, operates the Hafen cogeneration plant in Münster, Germany. It wanted to replace the original hard-coal-fired power station with a new gas-and-steam facility integrated into the existing cogeneration plant to modernize and enlarge it in compliance with German legislation.

The new system should consist of two separate gas turbines with downstream heat recovery boilers, from which fresh steam would be led to a back-pressure steam turbine to produce both electric power and hot water for district heating. In order to increase the share of self-produced electric power and achieve full-fledged cogeneration capabilities, the Hafen plant was modernized in 2004/2005 in cooperation with the Hamburg-based engineering firm of Electrowatt-Ekono GmbH.

### Technical Project Information

Number of Lines	1
Energy Source:	GT Flue Gas
Fuel for Auxiliary Firing:	Natural Gas, extra-light Fuel Oil
Electrical Power Output GT:	32 MW
Electrical Power Output ST:	38.7 MW
Steam Capacity:	2 x 81.5 t/h
Steam Temperature:	525 °C
Steam Pressure:	41-81 bar g
Feed Water Temperature:	105 °C
Nominal Waste Gas Flow:	95.7 kg/s
GT-Waste Gas Temperature:	504 °C
Max. Heat Output with Auxiliary Firing:	38 MW
Max. Heat Output in Fresh-Air Operation:	75 MW
Boiler Waste Gas Temperature:	80 °C
Year of Commissioning:	2005

### The Solution

Two Type RB 211 T gas turbines from Rolls Royce with a nominal output of 32 MW each were chosen for the new facility. The waste heat from each gas turbine is used by a separate downstream boiler to produce high-pressure steam and hot water for district heating.

Auxiliary firing of natural gas and extra-light fuel oil is used to increase the steam output in the combined GT operation and to ensure a supply of electric power and district heat by fresh-air firing during GT trip.

It is possible to switch between combined GT and fresh-air operation by "flying take-over", i.e. without interrupting steam production.

### Scope of Supply

- Heat Recovery Steam Generator with District Heating System
- Steel Construction, Stairs and Platforms
- Firing System
- GT Bypass System
- Stack

### Services

- Engineering
- Assembly
- Commissioning

# SOURCES OF ENERGY

## WASTE HEAT FROM INDUSTRIAL PROCESSES

Waste air and gases incurring from industrial processes are possible high-energy heat sources. This heat should be used. For example as heat recovery boiler plants being subsequently arranged according to the processes and converting the waste air and waste gases included in the energy in the hot water, process steam or power to proper supply.

<b>Heat source:</b>	Waste heat and gases from industrial processes
<b>Performance Range:</b>	Steam parameters up to 150 t/h - 500°C - 100 bar
<b>Auxiliary fuels:</b>	Coke-oven gas, blast-furnace gas, natural gas, fuel oil, production gases
<b>Boiler technology:</b>	<ul style="list-style-type: none"><li>• Steam generators with natural circulation in horizontal or vertical one or multi-pass construction with different pressure stages.</li><li>• Either designed as heat recovery boiler or equipped with auxiliary firing also suited for fresh air operation and „flying takeover“ between fresh air operation and gas turbine operation mode.</li><li>• The superheated steam temperature control is carried out by means of an injection cooler between the superheater heating surfaces.</li></ul>
<b>Combustion system:</b>	Industrial combustion systems as duct burners in the gas turbine exhaust duct or as in-duct burner in the combustion chamber of the boiler plant respectively. As gas turbine burner installed in the floor or in the surrounding walls of the water cooled combustion chamber of the boiler plant.

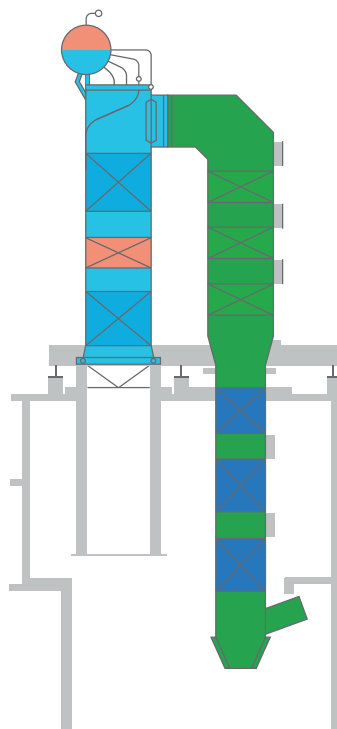

Example of a plant fired using the heat recovered from industrial processes



## Sample Reference Grovehurst, Great Britain

### The Task

So as to reduce environmental impact caused by land-filling and land-spreading of the produced waste-paper sludges from the paper making process at Kemsley and Sittingbourne site, a new combustion plant was planned to be built.

The energy company E.ON UK commissioned the companies Lurgi Envirotherm GmbH and Lurgi UK with the installation of a fluidised bed combustion plant containing a waste-heat steam generator situated next to the existing power plant at Kemsley Paper Mill. During the early conceptual design phase, Baumgarte Boiler Systems was already involved in the preparation of a concept tailored to build a waste-heat recovery system.

### The Solution

The experience gained from supplied and operative waste-heat recovery systems in comparable applications was the basis of the boiler to be engineered. When the flue gases leave the combustion chamber, they are directly conveyed to the main-steam generator in vertical design with the installation of evaporator walls, superheater and evaporator heating surfaces. The economiser heating surfaces are located in the second flue-gas pass made from sheet-metal casing. So as to provide cleaning of the heating surfaces, both passes are equipped with a steel shot cleaning system and also offers the option to retrofit a soot-blower system.

### Technical Project Information

Number of Lines	1
Fuel:	Waste Heat from Sludge Combustion
Flue-gas Flow (moisture):	79,400 m <sup>3</sup> i. N./h
Quantity of Flue-gas Heat:	33.75 MW
Flue-gas Temperature:	860 - 1,000 °C
Steam Capacity:	38.8 t/h
Steam Pressure:	26.5 bar g
Steam Temperature:	345 °C
Feed Water Temperature:	105 °C
Exhaust Gas Temperature:	160 - 180 °C
Air Rate:	45,000 m <sup>3</sup> i. N./h
Air Temperature Inlet / Outlet:	25/220 °C
Operating Approval:	Dampf KV
Year of Commissioning:	2002

### Scope of Supply

- Main-Steam Generator with Shut-Off and Control Devices
- Boiler Supporting Structure including Stairs and Platforms
- Steam Air Preheater
- Interconnecting Piping
- Cleaning System as Steel Shot Cleaning Plant
- Boiler Feed-Water Pumps with Fittings
- Blow-Down tank and Sampling Station
- Metrological Boiler Equipment

### Services

- Approval and Official Engineering
- Detail-Engineering and Technical Handling
- Erection, Commissioning and Trial Run



We can't do without them: oil, natural gas and coal still rank among the most important energy sources. However, with a growing global energy demand and ever stricter environmental protection guidelines, private and public energy suppliers as well as industrial companies are being forced to explore new paths with regard to utilising primary fuels and converting energy.

# ALL FIRED UP: ENERGY FROM PRIMARY FUELS

26/27



Numerous plants and systems successfully realised all around the world by Standardkessel and Baumgarte demonstrate how to jointly increase both the profitability and efficiency of power plants. These range from boiler systems fired with primary fuels up to complete industrial power plants which use the cogeneration principle.



# SOURCES OF ENERGY

## COAL

Coal or brown coal are always used as an important option for steam generation - subject to the mounting gas and oil costs worldwide. Price stability and security of supply are often decisive reasons for investing in a coal-fired powerstation.

<b>Fuel:</b>	Coal and lignite briquette, lignite dust Auxiliary firing: natural gas or fuel oil
<b>Performance Range:</b>	Steam parameters up to 360 t/h - 570°C - 190 bar
<b>Boiler technology:</b>	<ul style="list-style-type: none"> <li>• Steam generators with natural circulation with several boiler passes being vertically arranged.</li> <li>• The first boiler pass is formed as open pass and is divided into furnace and radiation chamber. Superheater, evaporator and economiser convection heating surfaces are installed in all further boiler passes.</li> <li>• All convection heating surfaces can be cleaned during operation with soot blowers.</li> <li>• The superheated steam temperature control is carried out by means of an injection cooler between the superheater heating surfaces.</li> </ul>
<b>Combustion system:</b>	<ul style="list-style-type: none"> <li>• Travelling grate firing with hopper feed and fuel bed controller.</li> <li>• The primary air is fed underneath the grate - divided into several separately controllable zones.</li> <li>• The secondary air injection is carried out via nozzle rows in the front and rear wall of the furnace.</li> </ul>
<b>Alternative:</b>	Low NOx industrial/powerstation firing systems are used for lignite dust. The burners are arranged depending on the capacity in the surrounding walls of the combustion chamber.
<b>Flue gas treatment:</b>	According to the requirements, e.g. following equipment are foreseen: cyclone system and electrostatic precipitator

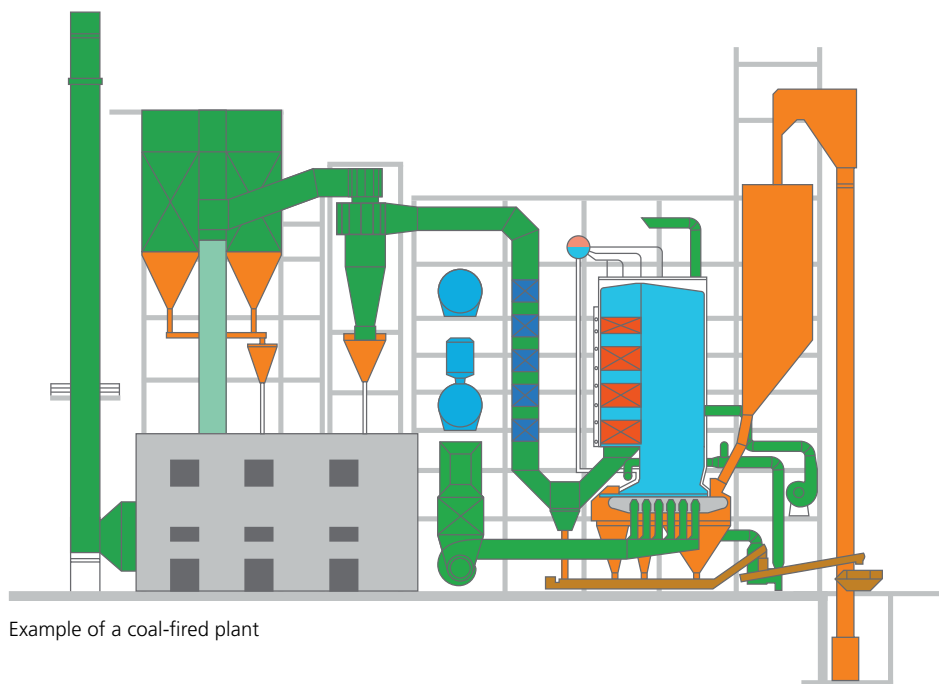

Example of a coal-fired plant



## Sample Reference Jülich, Germany

### The Task

Standardkessel has received the order from Zuckerfabrik Jülich AG for the supply of a steam generator including a flue-gas cleaning system.

### The Solution

The boiler with grate stoker-firing system is designed for the use of lignite briquettes, bituminous coal and fuel oil and supplies 130 t/h of superheated steam at 92 bar and 520 °C. According to the principle of cogeneration the steam is first used for the generation of electrical power and then used as process steam. The plant was put into operation in September and supplied already energy for the sugar campaign in 2004.

### Technical Project Information

Number of Lines	1
Fuel:	Lignite Briquettes
Low Heating Value:	19.8 MJ/kg
Fuel Throughput:	21.8 t/h
Fuel:	Bituminous coal
Low Heating Value:	28.6 MJ/kg
Fuel Throughput:	15.1 t/h
Thermal Input:	120 MW
Steam Capacity:	130 t/h
Steam Temperature:	520 °C
Steam Pressure:	92 bar g
Feed Water Temperature:	110 °C
Rated Flue Gas Volume (nom.):	168,500 m <sup>3</sup> i. N./h
Flue Gas Throughput:	145/160 °C
Operating Approval:	17. BlmSchV
Year of Commissioning:	2004

### Scope of Supply

- Coal Handling System, incl. Bunker
- Traveling Grate System
- Combustion Air System
- Steam Generator
- Steel Structure
- Cyclone
- Bag House Filter
- Flue Gas Conditioning System
- Slag and Ash Handling System

### Services

- Engineering and Supply
- Erection and Commissioning
- Putting in to Operation

# SOURCES OF ENERGY

## GAS & OIL

Despite mounting energy and fuel costs worldwide, gas and oil are still important fuels. High reliability in operation and important characteristics as quick-start and load change rates often facilitate the decision for gas and/or oil-fired boiler plants.

<b>Fuel:</b>	Natural gas, heavy fuel oil, fuel oil
<b>Performance Range:</b>	Steam parameters up to 360 t/h - 570°C - 190 bar
<b>Boiler technology:</b>	<ul style="list-style-type: none"><li>• Steam generators with natural circulation in compact construction, extensively prefabricated on the factory.</li><li>• Two drum boiler with natural circulation in modular construction.</li><li>• As multi-pass-boiler designed according to the specific project requirements.</li><li>• For the production of hot water, saturated steam or superheated steam.</li></ul>
<b>Combustion system:</b>	Low NOx industrial/powerstation firing systems as single-fuel system or as combined burner for liquid and gaseous fuels.

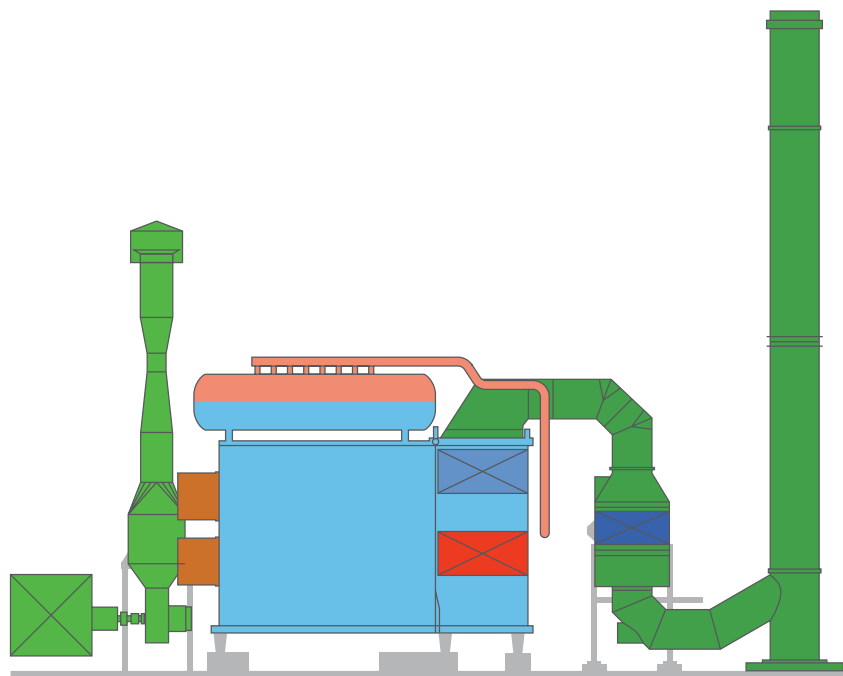

Example of a gas- and oil-fired plant



## Sample Reference Oman

### The Task

The main contractor MAN Ferrostaal AG required two natural-gas / fusel oil fired water-tubes boilers to ensure the supply of process steam to the new methanol-generation plant, with a capacity of 3000 t per day, to be installed in the Sultanate of Oman. The particularity of the task ahead for Baumgarte Boiler Systems GmbH were to ensure a continuous operation process during the first two years and to make the main steam parameters available as from 50 % of full load. In the case of main-steam generation failure, it was to be ensured that the steam generators be able to increase their load within 2.5 minutes from 50 to 100 % by maintaining its operating parameters.

### Technical Project Information

Number of Lines:	2
Fuel:	Natural Gas / Fusel Oil
Heating Value:	Gas 32.14 MJ/m <sup>3</sup> i. N. Oil 6.35 MJ/kg
Fuel Throughput:	Gas 4,830 m <sup>3</sup> i. N./h Oil 1,882 kg/h
Rated Thermal Input:	Gas 43.13 MW Oil 3.20 MW
Steam Capacity:	50.0 t/h
Steam Pressure:	30.0 bar g
Steam Temperature:	352 °C
Feed Water Temperature:	130 °C
Exhaust-Gas Temperature:	175 °C
Design Regulation:	TRD/DIN EN
Year of Commissioning:	2007

### The Solution

So as to comply with the set conditions, the steam generators were to be conceived as single-drum boilers in packaged constructions. All relevant boiler components, e.g. the evaporator system with steam drum were designed in full compliance with the given specifications. So as to match the requirements for a high availability, the major parts of the equipment components were designed for redundancy. So, the combustion air fan was equipped with two independent drives, i.e., turbine drive and electro motor.

### Scope of Supply

- Main-Steam Generators with Fittings
- Natural-Gas/Fusel-Oil Firing Systems with Combustion Air Fans
- Refractory of the Burner Openings
- Steam Turbine Drives for Combustion Air Fans
- Complete Electrical Control Systems
- Steel Structure for Stairs and Platforms
- Economiser
- Stack Plants and Flue-Gas Ducts
- Thermal Insulation

### Services

- Engineering
- Supervision of Erection
- Commissioning

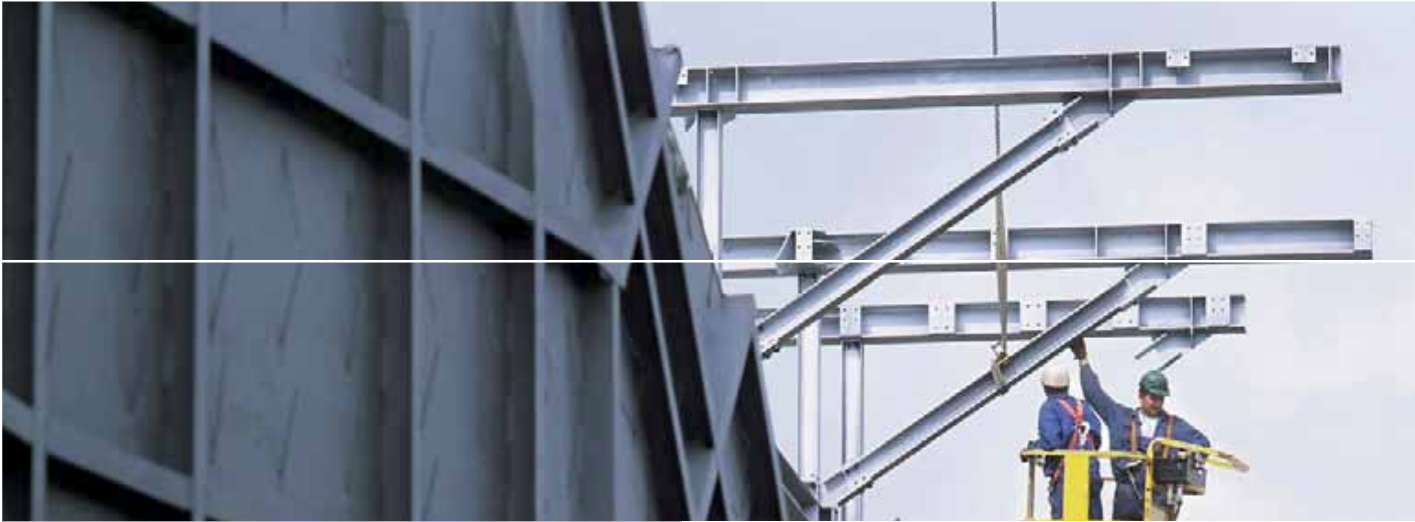

Our competence in the field of power plant activities is covering also a broad band of services. Starting with a wide spectrum of engineering works, we offer assembling and commissioning as well as optimisation, maintenance and plant operation.

We are ready to offer you a complete package of services tailored according to your specific requirements.



# SERVICE O.K.

32/33

# EVERYTHING O.K.



Engineering	task definition, check and evaluation of measurements and protocols, recommendations and proposals of measures, planning and engineering, execution of engineering works, quality control
Modernisation	definition of actual plant situation, definition of modernisation works, execution of modernisation works
Optimisation	conceptual design and realisation of: increase of availability, efficiency, reduction of emission values, operation costs, ect.
Maintenance	yearly power plant maintenance works, repairs, optimisation of components, spare part management
Erection	planning of erection, erection works and erection supervision, assembling of components and turn key plants, quality controls, erection management
Commissioning	functional check and settings of components, over all functional tests, performance checks and tests of components, preparations of test run, execution of test run including performance tests
Operation	power plant operation



## THICK NICKEL PLATING

### NEW, INNOVATIVE AND HIGHLY EFFICIENT

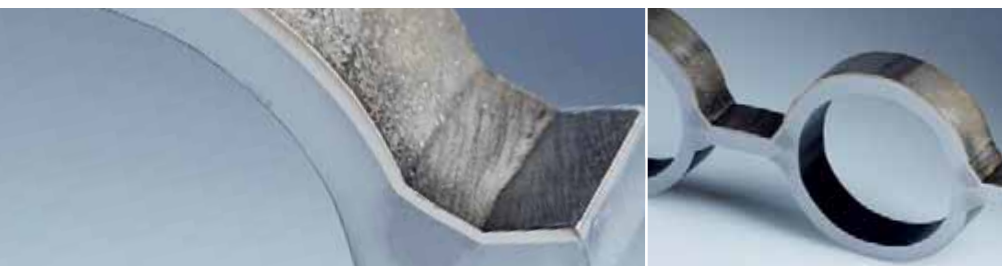

An essential element of an economically operating boiler plant is a smooth and reliable operation, without failures and expensive time-consuming maintenance measures.

As a leading supplier of plants for the combustion of disposals we are also the frontrunner in the development of new corrosive protection procedures, one of which is the thick nickel plating process which is exclusively licensed to Baumgarte Boiler Systems.

#### **Corrosion – the natural enemy of every plant**

Wherever flue gases with high temperatures come in contact with membrane walls and convection heating surfaces, corrosion can be formed.

The consequences: a reduced lifetime of the components so that a plant standstill to replace the damaged components can no longer be avoided.

A problem, which in particular crops up in plants for the combustion of disposals such as household waste, household-type industrial waste, refused-derived fuels and also in biomass combustion plants.

#### **The solution: thick nickel plating offered by Baumgarte Boiler Systems**

The process of thick nickel plating offers effective protection from corrosion.

This is an innovative procedure in which the components requiring protection are immersed in an electroplating bath made from 100 % nickel.

#### **The advantages are obvious:**

- The non-porous surfaces produced in the electroplating process protect the components from attacks by aggressive flue gases.
- The surface properties reduce the tendency for combustion residue to accumulate.
- Even large components and relatively complex forms can be effectively protected at little cost.
- The 100 % nickel is applied using a low tension technique, ensuring good adhesion.
- Unlike conventional processes, thick nickel plating does not mix with the base of the components.



### Application of thick nickel plating

The new innovative process of corrosion protection offered by Baumgarte Boiler Systems is suitable for heating surfaces with tube wall temperatures of max. 400 °C, such as:

- Membrane walls
- Convection evaporator
- Superheater
- Components in energy-generating plants prone to corrosion and fouling

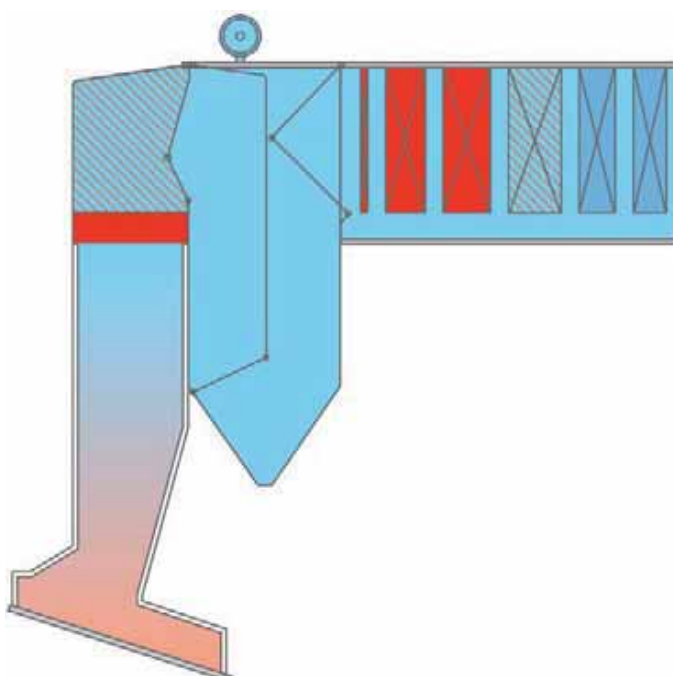

### Exemplary areas of a waste incinerator in tailend construction where thick nickel plating can be applied:

- High or increased potential of corrosion in the red and red-hatched areas.
- in other areas contacted by flue gas the application depends on the degree of damage by corrosion.

## TETRATUBE

### SYSTEM FOR OPTIMAL AFTERBURNING



#### The Task

Fuels occur in a very wide range of different qualities. Residues and in some cases biomasses falls into the lower end of this scale and this can be clearly seen during combustion in modern plants. In these plants, secondary air is usually injected at the front and rear walls of the furnace. This is not an ideal solution as the air jet is either too small or it does not reach deep enough into the furnace to produce sufficient mixing. In other

cases, the air jet is too large and overcools the afterburning flue gases. As a result, CO peaks occur which lead to corrosion in the boilers. This corrosion reduces the lifespan of vital boiler parts and results in high maintenance costs and long down times.

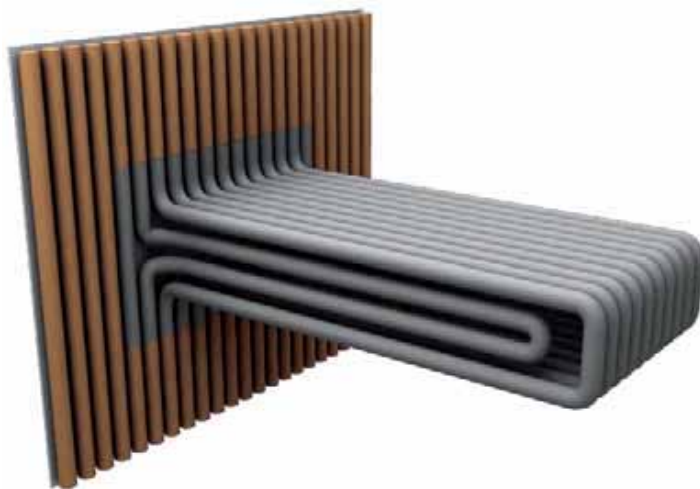



**The Solution**

With the patented TetraTube Standardkessel Baumgarte offers an innovative solution for optimum afterburning. It doesn't inject the secondary airflow from the side but delivers it to where it will be most effective: in to the top of the furnace. Constricting the boiler's cross section produces a kind of nozzle effect that causes the flue gases to mix perfectly with the injected secondary air. A second TetraTube, turned 90° and located approx. 2 m above the first, enhances the effect. At the most constricted point of the cross-section, the mixed

gases reach peak speeds of 30 m/s. These conditions are perfect for preventing peaks in CO and ensuring continuous afterburning. The system is also perfectly suited to injecting NOx reducing agents. The modified version is fitted in the furnace's corresponding temperature zone.

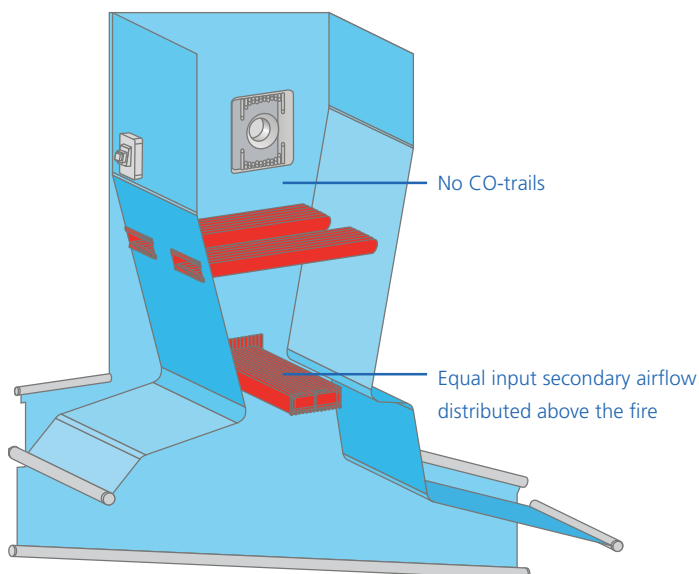

**New plant equipment with TetraTube**

## CUSTOMER REFERENCES

### PLANNED, BUILT AND APPROVED



#### **HOKAWE GmbH, Eberswalde, Germany**



“The decision to choose Standardkessel was partly based on the company’s impressive references for the plants and systems it has already realised. The references motivated us to cooperate with Standardkessel to develop a concept that features a level of efficiency and availability unique for a grate firing system. In particular, with the generous layout and design of the plant, we are ideally prepared for future developments. The excellent performance and operating results we are achieving today prove that our decision to choose Standardkessel was definitely the right one.

Since the plant’s commissioning in 2006, we feed 20 MW of electrical energy generated from local renewable raw materials to the power supply grid in the Eberswalde region and also provide the surrounding industrial plants with process steam.”

#### **Dr Martin Berz**

Managing Director and Partner, HOKAWE GmbH

#### **EBS-Heizkraftwerk Nehlsen AG, Stavenhagen, Germany**



“With the RDF power plant in Stavenhagen (Germany), we wanted to break new ground. Therefore, the search for the right partner was not easy at first. But in the end, we found Baumgarte, a company that expertly mastered the technically demanding job and adhered to its tight deadline. Even in the face of tricky details, Baumgarte’s experience of meeting such challenges shone through. We always found a good solution. The fact that the plant was ready for operation after just 22 months is proof of that.”

#### **Peter Hoffmeyer**

Chairman of the Board, Nehlsen AG



**Vattenfall Europe Hamburg AG,  
Hamburg, Germany**



“As soon as we decided to modernise our energy supply at the Tiefstack combined heat and power plant site, we immediately realised that this project would have to be handled by a company specialised in this area, a company with experience and a proven track record of references.

Standardkessel GmbH, Duisburg (Germany), optimally supported us in installing two gas and steam lines with waste heat steam generators in our plant, in order to raise the ratio of self-generated electricity and increase the cogeneration of heat and energy. The on-schedule completion and successful operation of the waste heat boiler system once again show just how important it is to have a reliable partner like Standardkessel, a company that excels at managing such projects.”

**Manfred Trübenbach**

Head of Generation, Heat Business Unit, Vattenfall Europe Hamburg AG

**Papier- und Kartonfabrik  
Varel GmbH & Co. KG,  
Varel, Germany**



“In 2006, we awarded Baumgarte the contract to supply our factory with Boiler 8 (output level 95 t/h, steam/95 bar). After just 11 months, the steam generator went into operation as a combined heat and power installation with two upstream gas turbines (6.3 MWel each). Since its commissioning, the plant has run flawlessly and we are completely satisfied. In addition to the price-performance ratio, Baumgarte’s expertise, reliability, flexibility and personal commitment were crucial factors that won us over.

The success of the new boiler once again affirms the trusting and excellent cooperation between Papier- und Kartonfabrik Varel and Baumgarte Boiler Systems.”

**Horst Büsing**

Managing Director, Papier- und Kartonfabrik Varel GmbH & Co. KG

Count on us to find the energy management ideas you need.  
Provided, of course, that you find us first:

**Standardkessel GmbH**

Baldusstrasse 13  
47138 Duisburg  
Germany  
Phone: +49 (0) 203-452-0  
Fax: +49 (0) 203-452-935  
info@standardkessel.de  
www.standardkessel.de

**Baumgarte  
Boiler Systems GmbH**

Senner Strasse 115  
33647 Bielefeld  
Germany  
Phone: +49 (0) 521-9406-0  
Fax: +49 (0) 521-9406-132  
info@baumgarte.com  
www.baumgarte.com

**Standardkessel Baumgarte  
Service GmbH**

Duisburger Strasse 375  
46049 Oberhausen  
Germany  
Phone: +49 (0) 208-2994-711  
info@skg-bbs-service.de  
www.skg-bbs-service.de

